



## User manual



### Easy Go

Van Raam  
Guldenweg 23  
7051 HT Varsseveld, The Netherlands

☎ +31 (0)315 – 25 73 70

✉ [info@vanraam.com](mailto:info@vanraam.com)

🌐 [www.vanraam.com](http://www.vanraam.com)

Version 23.07



# Table of contents

Manufacturer contact details .....	3
Conformity.....	3
Introduction.....	4
Delivery.....	4
Indication.....	5
Intended usage .....	5
Safety measures.....	6
Adjustments of the bike.....	9
Before first use .....	11
Operation .....	16
Electro system Silent .....	17
Van Raam e-bike app.....	28
Accessories.....	29
Technical specifications .....	31
Standardisation and CE-marking.....	32
Maintenance and adjustments by owner.....	32
Repairs and maintenance to be done by dealer .....	34
Adjustments to be done by dealer.....	35
Disposal.....	37
Handover/sale to a new owner .....	37
Guarantee .....	37
Frame number.....	38
Maintenance recommendation .....	39
Delivery and service form.....	43

## Manufacturer contact details

Van Raam

Guldenweg 23

7051 HT Varsseveld, The Netherlands

☎ +31 (0)315 – 25 73 70

✉ [info@vanraam.com](mailto:info@vanraam.com)

🌐 [www.vanraam.com](http://www.vanraam.com)

## Conformity

### Conformity Europe (CE)

Van Raam Reha Bikes B.V., as manufacturer, declares that the Easy Go, as described in this user manual, is manufactured in accordance with Regulation (EU) 2017/745, risk class 1.

The Easy Go supplied with the Silent electrical system also complies with Directive 2006/42/EC including the applicable parts of EMC Directive 2014/30/EU and the NEN-EN 15194:2017 Bicycles - Electric supporting bicycles - EPAC Bicycles - part 4.2 Electrical requirements. The signed declaration of conformity can be found on the Van Raam website.

### Conformity UK (UKCA)

Van Raam Reha Bikes B.V. as manufacturer declares that the Easy Go, as described in this user manual, is manufactured in accordance with the "Essential Requirements of Medical Devices Regulation 2002" (UK MDR 2002 Class 1 Medical Devices). The Easy Go supplied with the Silent electrical system also complies with the "Machinery (Safety) Directive SI 2008/1597" including the applicable parts of "Electro Magnetic Compatibility Regulations SI 2016/1091" and the NEN-EN 15194:2017 Bicycles - Electric support bicycles - EPAC Bicycles - part 4.2 Electrical requirements. The Easy Go is provided with UKCA label according to "EU Exit Regulations 2020/1478". The signed declaration of conformity can be found on the Van Raam website.

## Introduction

This user manual provides important and necessary information about the use of your scooter bike. We ask you to read this manual thoroughly before using the scooter bike.

Always follow the instructions as provided in this user manual and keep the manual carefully. The most current version of the user manual can be found on the product page of the bicycle on the website [www.vanraam.com](http://www.vanraam.com).



**READ CAREFULLY**

All safety and user aspects have to be made clear to children and to people with limited powers of perception by a responsible and supervising person.

## Delivery

The delivery should include the following:

- Scooter bike with packing
- User manual(s)
- Possible Smart-battery including card with 5-digit code (depending on options)
- Possible chargers (depending on options)
- (Spare) keys

Check the delivery immediately after receiving it. In case of damage or incomplete delivery we ask you to contact your dealer immediately. Upon delivery you should fill out the form "Form service, maintenance, modifications and warranty claims" in the back of this manual.

## Indication

The Easy Go is meant for adults with a fluctuating health status, who want to pedal but would also like to have the option of completely switching to electric engine if they cannot cycle (anymore).

## Intended usage

The Easy Go scooter bike (intended use: outdoors class B) is designed for normal use on a flat, solid surface. The Easy Go may be used at ambient temperatures ranging from -25 degree Celsius to +50 degree Celsius. In general, scooter bikes caution should always be observed when using the scooter bike. Moreover, the safety instructions as described in this manual should be explicitly followed. Local traffic laws and regulations should also be observed.

To ride the Easy Go a minimum age of 16 years is required. Besides this, the driver should be independently mobile and he/ she may not have any serious visual or other impairments, which prevent responsible participation in traffic. The maximum user weight and luggage weight (to be found in the chapter '**Technical specifications**') may not be exceeded.

The manufacturer is not responsible for any damage or injury caused as a result of or during the course of any other type of use.

## Safety measures



**Important:** Please read the safety measures before using the scooter bike!

- Ensure the scooter bike is in good condition each time before using it. Check before **each** ride that the brakes are in order. Check the lighting and make sure there is enough tyre pressure (recommended: 3 bar).
- Always get a punctured tyre repaired before using the scooter bike. To avoid damage to the wheels or other parts.
- Regularly check if the wheels, the handlebars and the seat are properly fixed and also that all the screw connections are tight enough.
- Only use the scooter bike on a **solid and flat surface**. Soft, slippery or uneven terrain increases the risk of dangerous situations.
- Make sure that wide trousers or loose hanging clothing don't get caught in the chain, spokes or pedals.
- Take care that fingers and limbs do not get trapped while folding up or down the footrest and armrests.
- Be aware of the protruding parts on the scooter bike. These could cause damage to the surroundings and the scooter bike.
- Do not use a pressure washer or a steam cleaner for the cleaning of the scooter bike.
- Use the parking brake when you park (and leave) the scooter bike. Use the parking brake, even while getting on or off the bike to prevent its accidental movement.
- Always switch off and lock the scooter bike when leaving it unattended. This prevents the unwanted use and / or theft.
- This scooter bike is suitable for transporting a single person.
- Only use original Van Raam parts and accessories.
- Ride carefully on roads that are slippery due to rain, ice or snow.
- Watch out for overturning when riding up a slope. The scooter bike is equipped with ascent limiters to limit the risk of overturning.

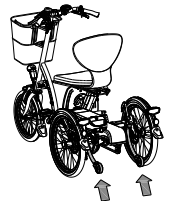

- Avoid slopes steeper than 6°.  
Riding this scooter bike (forward or in reverse) on steep slopes can be dangerous.
  - Please note that the stopping distance could be greater on a slope as compared to a horizontal surface.
  - Make sure that you do not reach a dangerous speed when driving downhill and entering tunnels. Brake in time and bike at a moderate speed.
  - Ride carefully along (pavement) edges. An uneven surface increases the risk of overturning.
  - Turn around carefully on a steep slope to avoid the risk of overturning.
  - Always get on and off a pavement in a forward straight line, using a curb cut. Do this at an appropriate speed.
  - The maximum bump height that you can get on and off is 5 cm.
  - In case of pregnancy, extra care is required owing to a higher risk of injury.
  - Do not leave the scooter bike in direct sunlight: the temperature of some parts could exceed 41°C resulting in possible burns to the skin.
  - When transporting the scooter bike in a motor vehicle, always make sure you are seated in a fixed seat of the motor vehicle. Scooter bikes may never be used as seating support in a motor vehicle, not even when the scooter bike is secured with a taxi restraint system.
  - Never lift the scooter bike holding the batteries or the plastic parts at the back.
  - Practise the reversing and acceleration functions of the electric motor. Always pay attention when you turn on the electric motor and do not be surprised by the sudden behaviour of the electric motor.
- Please be careful** not to switch on the reverse function of the electric motor inadvertently.

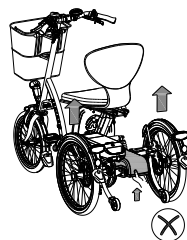
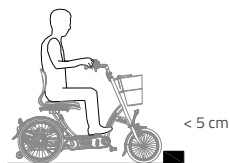
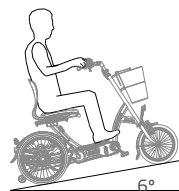

## Road safety

- If you are under the influence of medicines that may affect your ability to drive, you are not allowed to drive a scooter bike.
- Your vision must be adequate to drive the scooter bike safely in any situation that may occur during use.
- Please follow the relevant traffic rules that apply.
- Make sure that you are always noticed by the other road users. As a user of a scooter bike you are very vulnerable in traffic.
- Switch off the electrical system if you are using your mobile phone.
- You need to be at least 16 years of age to ride a scooter bike.
- Only enter the sidewalk or a pedestrian area in the scooter mode when the engine is active at level 1.

## Load

The maximum load should not be exceeded. See the information in the technical data table under the heading **“Technical specifications”** of the user manual. By permitted load we mean the total load, including the load in the basket or on the luggage rack.

Make sure that the permitted basket weight is not exceeded (**maximum 20 kg**). You may not carry passengers in the basket and you may not place luggage anywhere else on the bike. Do not allow anyone to stand on the rear side of your scooter bike.

Note that a basket full of luggage can considerably influence the driving. No luggage may be carried on the handlebars of the bike, as it limits the manoeuvrability of the scooter bike.

## Damaged or worn out parts

The replacement and repair of parts (frame, forks, light, brakes, drive mechanism and the handlebars) should **always** be performed by an authorised dealer. If not, the guarantee ceases to be valid and you will be personally responsible in the event of possible damage.



Specific safety parts should **always** be replaced by new parts!



## Adjustments of the bike

Before using the scooter bike, adjust it to the measurements of the driver. This is of great importance, especially the seat and the handlebars.



*If an optimal adjustment of the scooter bike, as defined in the instructions, is not possible, you can contact your dealer for a fitting solution.*

The brakes are correctly adjusted and should only be adjusted by the dealer during periodic maintenance.



Take care that fingers and limbs do not get trapped while adjusting the scooter bike.

### Seat

When the cyclist is sitting on the scooter bike and can put a foot on the pedal in the lowest position, the seat height is correct. Adjust the seat height in such a way that the leg is stretched but relaxed in that position.

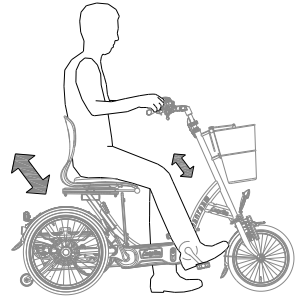

### Seat height

To adjust the height:

1. Loosen the two clamping levers.
2. Move the seat to the desired height and tighten the clamping levers.
3. Pull out the clamping lever and set it in such a position that it does not protrude.

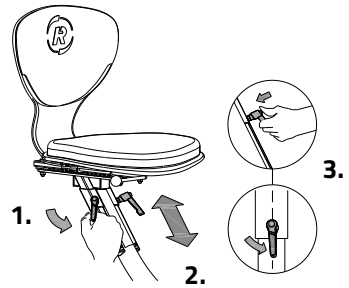

*Make sure clothing cannot get caught in the clamping levers!*



Ensure that the clamping levers are always firmly tightened, even with the seat in the lowermost position!

## Seat depth

To adjust the depth:

1. Pull the lever up.
2. Move the seat to the correct position and release the lever again.

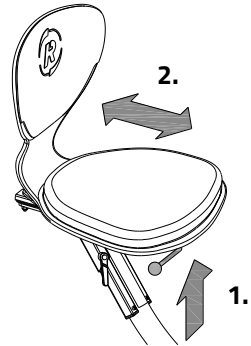

## Handlebars height

The height of the handlebars affects the comfort of the ride. It determines the pressure on the hands and the position of the back. You decide the most comfortable position yourself with some practice.

To adjust the handlebars:

1. Slightly loosen the screw by using an Allen key.
2. Move the handlebars to the correct height and tighten the screw very firmly again.

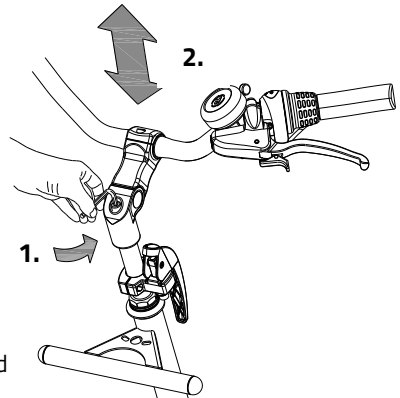

Do **not** pull out the handlebars **further** than the mark. Otherwise the tube will not be deep enough in the shaft and will risk coming off, which can lead to serious injuries.



## Position handlebars

You can tilt the handlebars. This influences the distance from the handlebars to the upper body. Determine your own most comfortable position by using the bike.

To tilt the handlebars:

1. Slightly loosen the screws [A] and [B] with an Allen key.
2. Put the handlebars in the desired position and then tighten the screws considerably.
3. Slightly loosen screw [C] with an Allen key, put the handlebars in the correct (horizontal) position and then tighten the screw again.

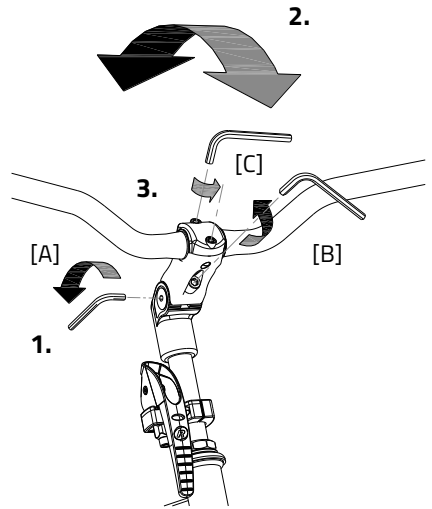

## Before first use

### Parking brake

Always use the parking brake if you park the tricycle and leave it behind.

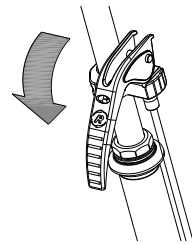

Block the tricycle with the hydro brake when passengers are getting on and off.

To operate the parking brake, squeeze the left brake [A] and secure the brake with the lever [B].

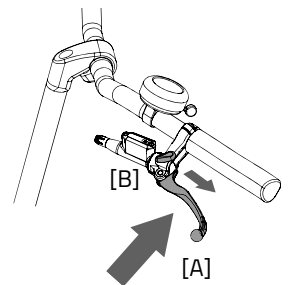

Always try to park the tricycle on a level surface. The tricycle may never be parked on a slope bigger than 6 degrees.

## Handle basket

The scooter bike is equipped with a handle basket. Hang the basket at the handle's bracket.



Ensure that the permissible basket weight is not exceeded (**maximum 20 kg**). Note that a basket full of luggage can considerably influence the driving.

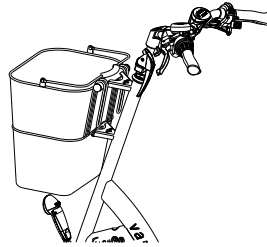
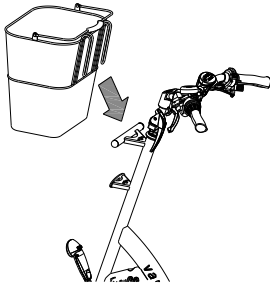
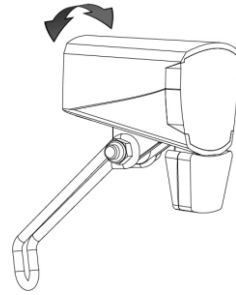

## Centrally Operated Lighting

The bike has been equipped with centrally operated lighting, with the lighting being connected to the electric system.

The lighting will turn on automatically when the electric system is activated.

Adjust the angle of the headlight, so that the centre of the light beam is aimed about ten metres in front of the bike.

You can manually turn the lighting on and off by briefly pushing the on/off button on the display. When the electric system is turned off, the lighting will turn of automatically.

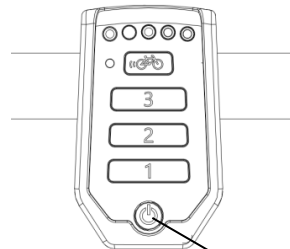

On/off button



*Make sure there is always a battery on the bike when you are cycling after dark!*

Once the battery is nearly empty, the motor will no longer provide pedal support power assistance while cycling. The lighting will still be powered by leftover power.

## Gears

The scooter bike has eight gears. The gear is operated by turning the grip.

**Do not use the pedals** when turning the grip.

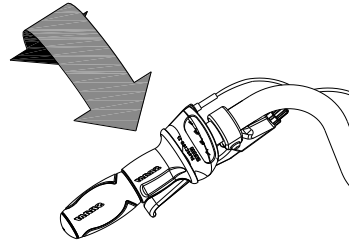

## Check before every ride:

- The brakes (including the parking brake)
- The tyre pressure (recommended: 3 bar)
- The lights
- That all the parts are fitted properly
- That the battery is adequately charged

Contact your dealer and stop using your scooter bike as soon as you observe irregularities during the check!

As with all mechanical parts, the scooter bike is subject to wear and tear and high loading. If a component fails, it can lead to very dangerous situations. This can lead to damage or injuries to the user of the scooter bike. Any form of cracks, scratches or change in colour in load heavily loaded parts of a component indicates that the component must be replaced.

## Points to remember while cycling

You can use the scooter bike once you have adjusted the scooter bike according to the measurements of the driver.



The tricycle gives a very different ride experience than a bicycle.

Practice, in particular, with bends and braking, because a tricycle may react contrary to your expectations. It may happen that the back wheel comes off the ground on the inside when going round a sharp bend. To avoid this the rider leans towards the inside of the bend with his body.

One of the brake levers (usually the right) operates the brake on the front wheel. This deserves special caution, as a forceful braking could block the front wheel, which could result in a fall. The driver should be familiar with controlled braking of the front wheel!



As the scooter bike is equipped with an electric motor: make sure that you practise with the acceleration and reversing functions. Be careful that the acceleration mode or reverse mode are not unintentionally started while using the scooter bike. For example: If you wait for the traffic light and you play with the pedals by moving them backwards the reverse function is activated and the scooter bike goes backwards.



High speeds in corners, on uneven terrain and extreme steering angles could lead to the **overturning** of the tricycle!



**Extra attention** is needed when a child or an adult with limited powers of perception uses the scooter bike! (The minimum age for riding the Scooter bike in traffic is 16 years.)

Before a child or an adult with limited powers of perception rides the scooter bike independently for the first time, they should practice first under your supervision (or under the supervision of others).

Pay special attention to the turning because it could lead to dangerous situations. Also explain to the driver that the widest part of the scooter bike lies behind him / her. Let him/her practise by riding over a few obstacles to get an idea of how wide the scooter bike is!

Children or adults with limited powers of perception should **always** be reminded about the possible dangers/ risks involved in using the scooter bike.

### **Important safety points for the rider**

- Be very careful during the first ride.
- When riding the scooter bike hold both hands firmly on the handlebars and feet on the pedals or the feet plate.
- Test the riding style of the scooterbike on rough ground at moderate speed. This way the cyclist learns how to react to unexpected movements of the scooterbike and the handlebars during use.
- Explore how the tilting movements of the scooter bike react to body posture. Tilt to the inside of the bend.
- Small obstacles should be cycled over with appropriate speed.
- Obstacles higher than five centimetre should be avoided.
- Ensure that no dangerous speed develops while driving downhill and entering tunnels. Brake on time and cycle at a moderate speed.

## Operation

The scooter bike can be used in two different ways, as a cycle and as a scooter. These two modes can be interchanged simply by folding the footplate (with the hand or foot). When you have folded down the footplate, the bike works as a scooter and when you fold it up, you can pedal along. In the cycling mode, you can even use the throttle as an extra support, if required.

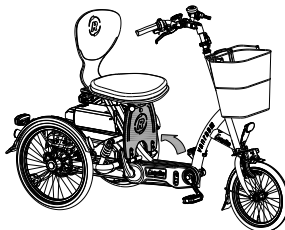
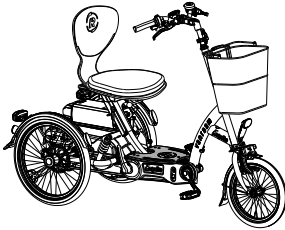

### 1. Scooter mode:

- Footplate down.
- Ride forward and backward with the thumb throttle.
- Pedals are disengaged.

### 2. Cycling mode:

- Footplate up.
- Driving activated by pedaling.
- Power assistance depending upon pedaling power and speed.
- Extra assistance with the help of the thumb throttle.
- Reverse riding by reverse pedaling.



*When getting on, first take your place on the seat, and then you can lift your legs safely across the frame or the footplate. This way you can avoid being stuck or slipping on the footplate, which can be slippery when it is wet.*



## Brakes

The handbrakes should be used for coming to a standstill, in the cycle mode as well as the scooter mode. The parking brake should be used to avoid the scooter from rolling away on its own when left unattended.

## Electro system Silent

The Silent Electric motor system is a special developed support system by Van Raam for the rehabilitation market. The system is characterized by:

1. A simplicity of operation
2. Individually adjustable support for cycling
3. Modern and efficient electronics
4. The powerful electric motors
5. High quality and safe batteries
6. Highly reliable system

The Silent system comes standard with a basic support mode individually programmed for your scooter bike. In most cases, it gives precise and smooth cycling characteristics with a good compromise between support and radius of action.

In special cases, an individually tailor-made cycling program is necessary. You can obtain information from the dealer about the possibilities of a customised cycling program.

## Functions

The electric system has the following functions:

- Pedal support while cycling
- Start support
- Backwards pedalling with support
- Full electric drive
- Integrated lighting control

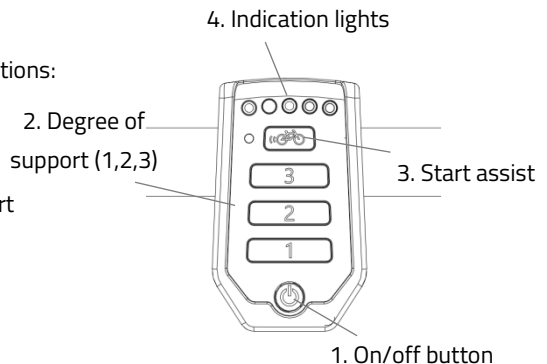

## 1. On/off button

Using the on/off button, the electrical system can be switched on or off.

- Switching on: Push the button briefly.
- Switching off: Push the button for two seconds.

After the system is turned on, the electric motor is active in level 1.



*When the system is not used, it will automatically turn off after a certain time.*



Always turn off the electric system before getting on and off the bike, and when you are walking while holding the bike.

## 2. Degree of support 1, 2 and 3

The desired support can be set by using one of the support levels 1, 2 or 3.

1. Light support, maximum range.
2. Average support, average range.
3. Maximum support, low range.

You can change the level while cycling.



*The behaviour of the battery depends on a lot of different factors and is strongly influenced by: capacity and voltage of the battery, degree of support that is used, temperature, wind speed, tyre pressure, cycling speed, weight of the user and the luggage, use of gearing etcetera.*

### 3. Start assist

The start assist is not available with the Easy Go scooter bike.

### 4. Indication lights

The level of charge in the battery is given by five LED lights: four of these are green, the one on the left can show either green or red, if charge is low.



The battery is fully charged. When in use, the number of green LED lights on the battery will decrease.



The battery is 50% charged when two green LED lights are on.



The battery is almost empty if only the last red LED light is on. The battery needs to be recharged or replaced by a (new) fully charged battery.



When the last red LED light flashes, the battery is empty and the motor will no longer support while cycling. The integrated lighting continues to work.

The battery is equipped with a button and indicator that makes it possible to check the charge by briefly pressing the button [A]. The status of the battery is shown with five green indicator LEDs, of which the left most one can blink. That means the battery is nearly empty. During charging, the battery displays the progress of the charging.

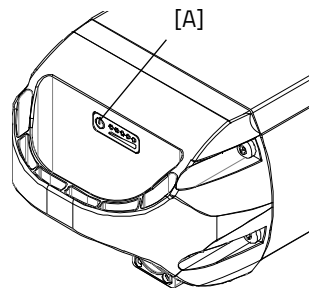

## Reverse mode

The reverse mode is activated by pedalling backwards from a standing position. Within a few seconds the motor is activated and the scooter bike cycles at a speed of about 2 km/h backwards (when you start to pedal backwards).



Do not be startled by an unexpected reaction from the electrical system. If you e.g. wait for the traffic light and you play with the pedals by moving them backwards the reverse mode is activated and the scooter bike cycles backwards.

## Full electric drive

In the scooter mode, the electric motor operates with a thumb throttle. Using the support levels 1, 2 and 3, you can attain higher or lower speed.

With the forward / reverse switch you can control direction.

0 = forward

- = reverse

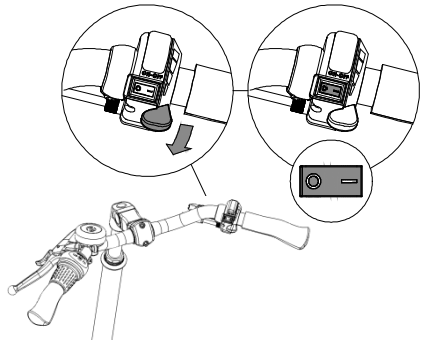

There is no option to change the maximum speed in the reverse mode. The LED lights of the support levels 1,2 and 3 burn to indicate that the reverse mode is activated.



Do not use support level 2 and 3 on the sidewalk or in a pedestrian area.



When you switch on the electrical system, all green lights on the display will turn on for 2 seconds. Please wait those 2 seconds until only one green light is on, before using the thumb throttle.

## Centrally Operated Lighting

The bike is equipped with centrally operated lighting, with the lighting automatically turning on when the electric system is activated. Further instructions can be found in the chapter '**Before the first use**'.

## Other functions

The smart display has an automatic dimming function. With an inbuilt light sensor the lights of the display will automatically creating less distraction for the cyclist in darker or more shadowy conditions.

## Charging the Battery

For the best performance and to prolong the life of the battery, we recommend that you charge the battery at home at room temperature.



Only use the charger if the temperature of the environment is between 0 and 35 degrees centigrade.

To charge the battery:

1. Unlock the battery by turning the key a quarter.
2. Push down and hold the lock. Then pull the battery out of the holder with your other hand.

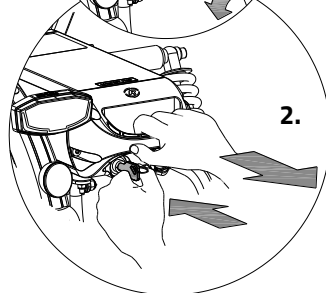
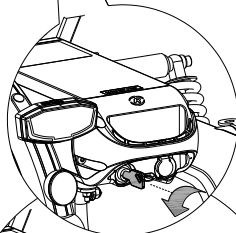
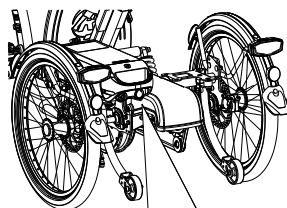

3. Take the battery pack inside. **First** plug the charger into the socket. The green LED will light up. The charger is now on standby.
4. **Then** insert the connector of the charger into the charging point of the battery. The red LED will light up. The charger is now charging.



**Please note!** If the battery is not connected properly, the green LED will light up (standby mode). If the connection is poor, unplug the plug from the socket and clean the charger's connector with a dry cloth.

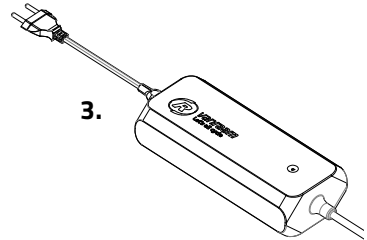

5. The charging time depends on the level of the battery. The charging time is approximately 2 hours with a 11,4 Ah/36 V battery and approximately 4.5 hours with a 24,8 Ah/36 V battery.
6. Once the battery is fully charged, the green LED will be solid. Now **first** remove the charging connector of the charger from the connector of the battery.
7. **Then** unplug the charger from the socket.
8. Put the battery back in the holder of the cycle and close the lock.

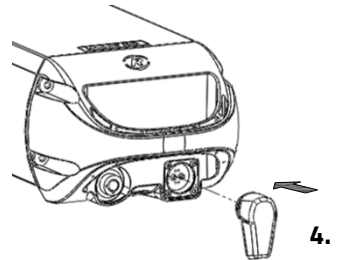

If necessary, the battery can also be charged directly on the cycle.

Charger:

LED indication	Status
Green	Standby
Red	Charging
Green	Battery full
Red, blinking	Safety: Polarity inversion; Short; Over temperature; Over power; Over voltage



It is better for the battery if it is charged regularly, rather than wait until it is completely drained. Never leave the bike with a drained battery!



Ensure that the battery is always pushed **straight** into the holder.

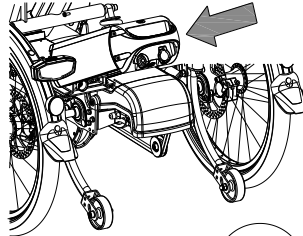
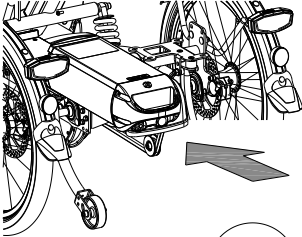

### Backup battery (optional)

The bike can be supplied with a second battery. When the first connected battery is empty, switch over to the second battery.

One of the battery holders is connected to the system, you can recognize this one because of the cables.

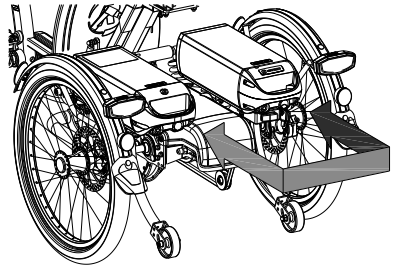

### Switchable battery pack (optional)

The bicycle may be fitted with a switchable battery pack. Once the connected battery is empty, you can swap the battery using a switch. This switch is located either under the seat, below the luggage rack or below one of the two batteries.

Both of the battery holders are connected to the system. If desired, you can leave the second battery to charge when you are using the other.

## Battery Deep Sleep Mode

When the battery is nearly empty and has not been used for a week, the battery will enter deep sleep mode. In this mode the battery uses as little power as possible, to increase the lifespan of the battery.

When the battery is in deep sleep mode, it cannot be used. By pressing the button on the battery, the battery will be woken up from deep sleep mode, and it can be used again. It is recommended to first charge the battery before using it in that scenario.

## Charging and maintenance tips for the battery

- Never leave the bike with an empty battery! We advise you charge the battery as soon as possible before it's totally empty.
- The best storage-charge of the battery is when three to five LED lights are lit.
- Check the battery every month in the winter. If fewer than three LED lights burn, recharge the battery.
- Preferably store and use the battery in environments of 5 to 20 °C. Avoid higher or lower temperatures.
- Do not charge the battery in sunlight and make sure that the battery is not charged at a temperature of less than 5 °C.
- Only use the charger indoors and in non-humid environments, the charger should *not* get wet.
- Only use the Van Raam supplied battery.
- Only charge the battery with the supplied charger!
- The battery housing and charger housing may never be opened! When there is a problem, contact your dealer.
- The Van Raam battery may not be revised due to serious safety risks and the incorrect functioning of the electric system as a whole.
- Don't drop the battery, this can cause external and internal damage.
- If your bicycle has a fault, the battery should be disconnected from the bicycle.



*Keep in mind that your bike provides less support when it's cold (0°C and less) and the battery will discharge faster. Charging also takes more time at lower temperatures.*





*Every battery discharges automatically over time. This process is called self-discharge. A battery that is empty and not charged, will self-discharge and will be deep discharged. The battery can be permanently damaged during this process. In case of deep discharge, the warranty will be void.*



*Please note that any battery will wear over time. The wearing process of the battery is inevitable and depends on several factors, such as usage, number of charge cycles and the ambient temperature. Even if the battery is not used, its capacity will decrease. A worn battery can still be used, but please bear in mind that its charge level may decrease.*

### **Possible malfunctions**

- The system does not turn on:
  1. Make sure that the battery is properly attached.
  2. Check the status of the battery. If it is empty, recharge the battery.
  3. If the above action does not help, contact your dealer.
- If the battery indicator LED lights on the display are flashing:

The motor may be overheated by continuous high load. For protection, the system will reduce the support.

  1. The system is in temperature-protection. You can continue cycling with reduced support.
  2. After cooling down, the normal support and indication will restore automatically.
- If the support LED lights on the display are flashing:

This indicates motor failure. You will need to contact your dealer.
- If a red LED light on the charger starts flashing, remove the plug from the mains outlet and do not longer use the charger. In this case, contact your dealer.

## Charger Safety Measures

- Only charge Van Raam Li-Ion batteries with the included charger. Only connect the charger to a suitable power point (220-240 Volt AC 50-60 Hz). If the charger is not being used, unplug it from the socket and take the plug out of the battery.
- The charger may only be used by people who have read the information in this user manual and are familiar with the proper use of the charger. Keep the charger out of reach of children; do not let them play with it.
- The charger has been designed for use in a dust-free, dry, and ventilated environment. Do not expose the charger to water, heat sources, and direct sunlight. Keep the charger clean and dry.
- Do not charge batteries that feel hot to the touch. The battery may not be hotter than room temperature for charging. Stop charging if the battery becomes abnormally hot ( $>40^{\circ}\text{C}$ ).

**Please note!** The charger may become hot during charging  $> 50^{\circ}\text{C}$ . First carefully feel if it is safe to touch the charger. This temperature can cause sensitivity or startle if it comes into contact with the skin.

- Do not use the charger if it is visibly damaged or modified. Do not repair the charger! Please contact Van Raam. Never open the charger yourself!
- While charging, please monitor the charger and the battery. Once the battery is full, remove the plug from the socket and the plug out of the battery.

## Direction Indicator

The scooter bike can be equipped with a direction indicator.

To operate the direction indicators, press switch [A] on the handlebar to the left or right. When the direction indicator is active, a clicking sound can be heard.

To deactivate the direction indicator, you need to set the button to the middle position.

The direction indicator is powered by the battery of the Silent Electric System.

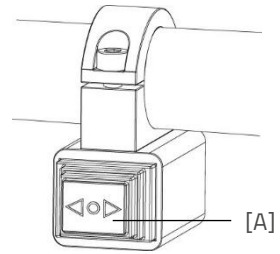

## Van Raam e-bike app

The Van Raam bicycle app is a free smartphone app that you can use while cycling on your electric Van Raam bicycle.

### What can you do with the Van Raam e-bike app?

It depends on the type of battery you have; a battery without a yellow GPS sticker or a battery with a yellow GPS sticker.

#### I have a battery without a yellow GPS sticker

- App can be used as a luxury bicycle computer
- Change bike settings
- Send SOS messages with GPS location to a number of your choice
- View cycled routes
- View information about the bike

#### I have a battery with a yellow GPS sticker

If you have a battery with yellow GPS sticker, then the above functions are also possible. In addition, some functions are added, namely:

- Pairing battery
- View battery data
- Receive battery advice
- Receive push notifications

#### How does the Van Raam e-bike app work?

With the Van Raam e-bike app, a connection can be made with the display via Bluetooth connection. As soon as the display is ready to connect to the smartphone, the on/off button will briefly turn blue.



This app can be used as a luxury bicycle computer for Van Raam bicycles with pedal assistance and also contains many other extra functionalities. The dashboard on the app shows the current speed, total distance, trip meter, battery capacity and power consumption during the bike ride. For more cycling data, there is a details screen including average speed, maximum speed, total distance, power, battery voltage, pedaling power and pedaling frequency.

The Van Raam e-bike app can be downloaded free of charge from the **Google Play Store** or **Apple App Store**.

For more information about the Van Raam e-bike app, you can visit the Van Raam website: [www.vanraam.com](http://www.vanraam.com).

## Accessories

Depending on your order, you can use the accessories as described below.

### Armrest

To get on the scooter bike easily, the armrest can be switched upwards. Once seated, you can bring down the armrest again.

The armrests are suitable for resting the arms on and as support when getting on and off the bike.

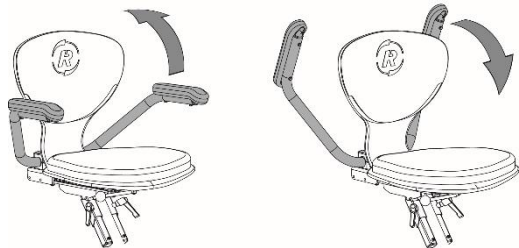

*Take care that fingers and limbs do not get caught in between while folding the armrest!*

## Lap belt

Take the belt across the body and click it into the clamp.  
Push the red button to unfasten the belt again.

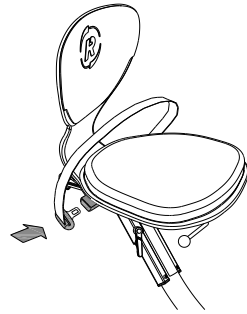

## Crank shortener

The crank shortener is fitted to the crank, as illustrated.  
The pedal can then be fitted into the crank shortener at two positions.

With the Allen screw [A] the crank shortener should be aligned with the crank.

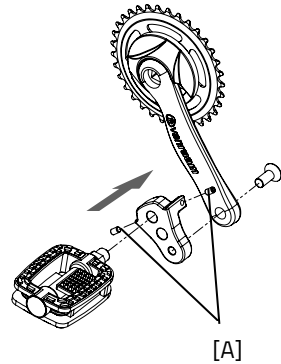

## Walking-stick holder

De stokhouder is bevestigd onder de zitting. De  
stok(ken) dienen te worden vastgezet met het  
klittenband [A].

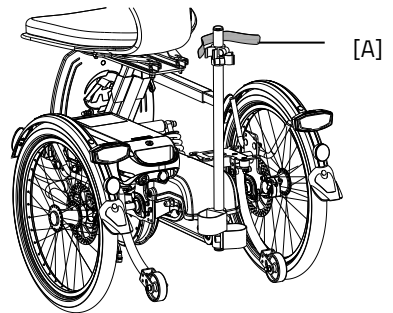

## Technical specifications

Length (cm)	166
Width (cm)	72
Frame height (cm)	115
Boarding height (cm)	29
Front wheel	16"
Back wheel	20"
Type of tyres	Pneumatic tyres
Weight (kg)	approx. 64
Brakes, front	Hand brake
Brakes, back	Hand brake
Battery	Li-ion 36V
Intended use	Outdoors (Class B)
Max. static stability downhill	10°
Max. static stability uphill	10°
Max. static stability on a lateral slope	10°
Max. dynamic stability uphill	6°
Max. safe gradient	6°
Max. obstacle height (cm)	5
Max. obstacle to be driven on to (sidewalk) (cm)	5
Max. loading of luggage basket / carrier (kg)	20
Max. user weight (kg)	140

Max. permissible load (kg) combination user and luggage	160
Max. speed with fully electric system (km/h)	15
Turning radius (cm)	180
Action radius* (km)	35
The Easy Go is normally delivered with three levels for the speed; 5 km/h, 10 km/h and 15 km/h	
Gas operation using thumb throttle, or electric assistance while pedaling.	

\* With the standard battery (11.2 Ah), fully electrical operation with normal use.

**Beware!** The action radius depends on a lot of different factors and is strongly influenced by: capacity and voltage of the battery, degree of support that is used, temperature, wind speed, tyre pressure, cycling speed, weight of the user and the luggage, use of gearing etcetera.

## Standardisation and CE-marking

The scooter bike is designed and tested in conformance with the EN 12184 Standardisation. The scooter bike complies with the provisions specified in the directive for Medical Devices and is provided with a CE-marking.

## Maintenance and adjustments by owner

Below you can find the instructions for maintenance and adjustments that you can do yourself on a regular basis, which will keep your scooter bike in top condition.

### Cleaning

The frame of the scooter bike can be cleaned with a damp cloth. For areas that are dirtier you can use a mild detergent.

The wheels can be cleaned with a moist brush with plastic hairs (not a wire brush!).



The grips, seats and upholstery of the seat and back can be cleaned with a damp cloth and mild detergent.



Do not use a pressure washer or a steam cleaner!

### The right lubricant

The chain should be cleaned and maintained at regular intervals (every three months approximately). Only use special chain grease or Tevlon spray. This is the only way to make sure that the chain will run smoothly, will stay water resistant and will not rust.

1. Wipe the chain with a cloth.
2. Treat it with grease or spray.
3. Remove any excess lubricant with a rag.

Other parts should **not** be treated with a lubricant.

### Inspection of the scooter bike

It is recommended that the scooter bike has a yearly inspection carried out by the dealer to claim warranty. Please use the form "Form service, maintenance, modifications and warranty claims" in the back of this manual. After 200 kilometres or after a period of two months the scooter bike should be inspected.

In the event of technical trouble or faults, the scooter bike should be taken to the dealer for repairs **immediately**.

The replacing of safety-related components (especially frame, brakes, lighting, handlebars, front fork and actuation) should be performed by the dealer.

If you still decide you want to replace components yourself, you are responsible for damage or harm due to incorrectly fitted components.

Only use **original** Van Raam spare parts, which you can buy at you dealer. If requested the dealer will make the necessary information on repair and maintenance available.

## Repairs and maintenance to be done by dealer

Check the brakes, the rims, lighting, the chain tension and the spokes. Also check the tyre tread depth. This should be at least one millimetre. Worn out tyres or possible faulty parts should be replaced. Also check the parking brake. With the parking brake pulled up, the scooter bike should not ride away with the cyclist.

### Checking the rim

Due to the combined action of the brake and the rims, not only the brake lining but also the condition of the rim is important. For this reason the rim should be checked at regular intervals, for example when you inflate the tyres. The presence of fine cracks in the spoke punches or deformation of the rim when there is higher air pressure, indicate more serious wear and tear. In that case the rim should be replaced, because it can lead to loss of brake function or even a crack in the rim, which can lead to all kinds of dangerous consequences.

Repairs, maintenance and modifications should only be performed with original Van Raam parts.

## Adjustments to be done by dealer

### The correct tension of the chain

Several chains are present on the scooter bike. The chains should not be too tight. Without efforts you should be able to move the chain up and down, about half a centimetre.

### Adjusting the chain tension of the foremost chain

To keep the foremost chain of the scooter bike tight, secure the chain tension wheel. To do this, follow the instructions given below:

1. Loosen the cap nut a few turns with a socket spanner.
2. Move the chain tension wheel, so that the chain is under light tension, as described above.
3. Tighten the cap nut again.

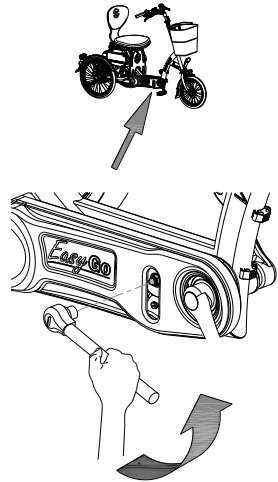

### Adjusting the chain tension of the hub chain

In order to tighten the hub chain, the hub is adjusted. To do this, follow the instructions given below:

1. Loosen the nuts of the hub with a socket spanner a few turns, so that the hub can move back and forth.
2. Tighten the nuts on the two chain tensioners, so that the hub slides back and the chain is tightened. Tighten the chain till the tension described above is reached. (Remember to tighten both the nuts equally.)

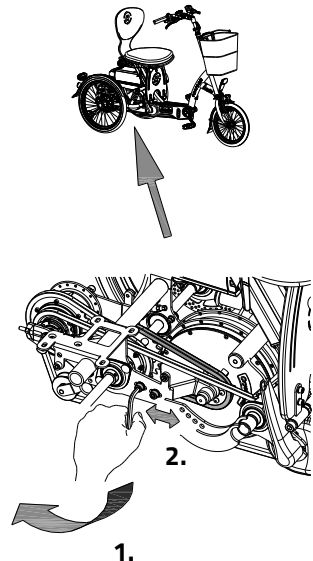

3. Tighten the nuts of the hub slightly.
4. Check if the chain tension is correct.
5. Tighten the nuts firmly.

### Adjusting the chain tension of engine chain

In order to maintain the correct chain tension of the engine, the engine is adjusted. To do this, follow the instructions given below:

1. Loosen the socket screws of the engine bracket with an Allen key a few times, so that the engine can move back and forth.
2. Tighten the nuts on the two chain tensioners so that the engine slides forward and the chain is tightened. (Remember to tighten both the nuts equally.)
3. Tighten the socket screws of the engine bracket slightly.
4. Check if the chain tension is correct.
5. Tighten the nuts firmly.

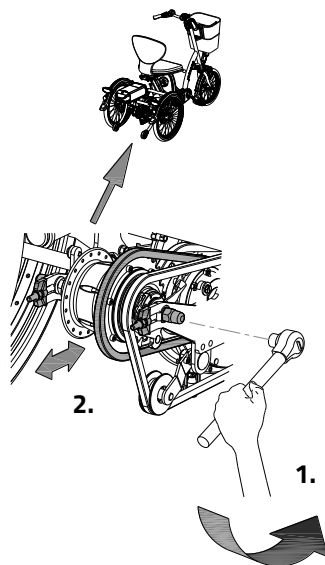

### Adjusting the suspension

The suspension is set at the factory. There are four positions possible. The suspension can be set as lighter or heavier by assembling the socket screws in different positions.

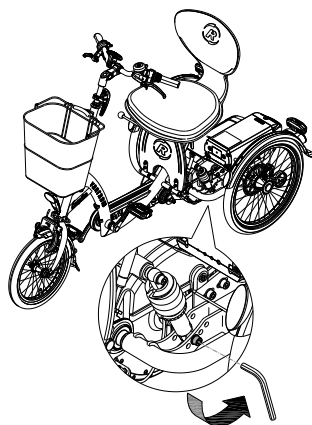

**Caution:** This handling should **always** be done by a dealer.

## Disposal

If you want to dispose your tricycle, contact your dealer. You can also contact the local waste disposal company. They will dispose the tricycle according to the regulations of your town.

## Recycling the Battery

If your battery is defective or if you are no longer using it, you must have it recycled. Please contact your dealer. They are responsible for complying with the recycling obligation. Ask them about the conditions or view the rules regarding recycling in your place of residence/country.

## Handover/sale to a new owner

When you hand over your scooter bike to a new owner it is important that you also hand over all necessary technical documentation and spare keys, so that the new owner can use the scooter bike safely.

## Guarantee

The guarantee is valid for all faults in the product, which are proven to be caused by material or manufacturing error.

We give a guarantee of five years on the frame and the front fork. For all accessories and other parts (except wear parts) we provide a two year guarantee, as legally regulated. The guarantee only applies for normal use and maintenance of the scooter bike, as described in this manual.

## Beware!

The guarantee as well as the product liability in general expires if the instructions stated in this manual are not followed. This is also the case if unauthorized maintenance is carried out or if technical changes or additions are made with non-original Van Raam parts without permission of Van Raam. The original CE certification will become nul-and-void if

modifications are done by third parties. The absence of the certification can lead to problems in insuring your bike, and for any loss or incurred.

## Frame number

The frame number is printed on the sticker. This sticker is located on the frame, see illustration.

Example of sticker:

Fabrikant/ Hersteller/ Manufacturer	Van Raam	Voor gebruik handleiding lezen
Voertuigtype/ Fahrzeugtyp/ Vehicle type	Easy Go	Vor Gebrauch Anleitung lesen
Bouwjaar/ Baujahr/ Year of production	2016	Read instruction manual before use
Voertuigidentificatienummer/ Fahrzeug-Identifizierungsnummer/ Vehicle identification number	XXXXX	Van Raam BV Aaltenseweg 56 7051 CM Varsseveld The Netherlands T +31 (0)315 257370 www.vanraam.com
Maximaal toelaatbaar totaalgewicht/ Zulassiges Gesamtgewicht/ Admissible total weight	224 kg	
Toelaatbare aslasten/ Zulässige Achslasten/ Permissible axle loads	44 kg as 1/ Achse 1/ axle 1 180 kg as 2/ Achse 2/ axle 2	CE

Position of sticker:



## Maintenance recommendation

A Van Raam bike often is subject to extensive use and must perform in all weather conditions. By correctly maintaining the bike, the lifecycle can be extended greatly. This maintenance can be done by a Van Raam dealer. In most cases, you can do the monthly and annual inspection yourself.

### Maintenance Overview:

What	One-person bike	Multi-person bike	Duration	By whom?
1 <sup>st</sup> service moment	3 months/300 km	3 months/200 km	15 min	Dealer
2 <sup>nd</sup> Service moment	6 months/1.000 km	6 months/500 km	15-30 min	Dealer
3 <sup>rd</sup> Service moment	12 months/2.000 km	12 months/1.000 km	30-90 min	Dealer
Monthly inspection*	Every month	Every month	15 min	User
Annual inspection*	Every 12 months	Every 12 months	60 min	User

\* This is advised to extend your bike's lifecycle. You can also have this done by your dealer.

#### Monthly inspection

15 minutes

Among them:

- Check and inflate the tyres
- Check the chain tension and grease if needed
- Tighten bolts/nuts where needed
- Check all lights
- Check the brakes
- Check all rotating parts and grease if needed
- Clean the bike

#### Annual inspection

60 minutes

Among them:

- Check and touch up the paintwork
- Check the wheels for any buckling
- Check the spoke tension
- Check the steering ball joints
- Check all lights
- Check the saddle clamp
- Check the placement of all electric components (E-Bikes only)

### **1<sup>st</sup> Service moment**

15-30 minutes

Among them:

- Check tyres and inflate
- Check the spoke tension
- Check the chain tension and grease
- Tighten any bolts and nuts if needed
- Check all brake cables and brake calipers
- Check the gears
- Check and grease all rotating parts
- Check all lights
- Clean the bike

### **2<sup>nd</sup> Service moment**

30-90 minutes

Among them: All points from service moment 1, and:

- Inspection of the pedals and bottom bracket
- Grease and tighten the lock
- Grease and tighten the steering stem
- Check the steering ball joints
- Run all tests in the dealer tool (E-Bike)

### **3<sup>rd</sup> Service moment**

60-120 minutes

Among them: All points from service moment 1, 2, and:

- Inspection of the paintwork
- Inspection of the frame/front fork
- Inspection of the seat cushions
- Inspect the functioning and sound of the motor/gear hub
- check reflectors for any damage
- Check all electric components on their placement (E-Bike)
- Run all tests in the dealer tool (E-Bike)



## Service plan

### 1<sup>st</sup> Service moment

- Yes/No
- Dealer:
- Mechanic:

Date:

Remarks:

.....

.....

.....

.....

### 2<sup>nd</sup> Service moment

- Yes/No
- Dealer:
- Mechanic:

Date:

Remarks:

.....

.....

.....

.....

### 3<sup>rd</sup> Service moment

- Yes/No
- Dealer:
- Mechanic:

Date:

Remarks:

.....

.....

.....

.....

## Annual inspection

Date	Dealer	Mechanic	Remarks

## Delivery and service form

Congratulations on your purchase of your Van Raam scooter bike. This bike is produced with utmost care. To guarantee the quality as much as possible Van Raam produces the cycles according to the ISO 9001:2015 quality standards. Van Raam has been certified by DNV GL Business Assurance BV.

You will especially enjoy your Van Raam bike when the bike is adjusted to your specifications and when the instructions in the user manual are followed. Pay special attention on the service intervals who specified in the manual of the bike.

To claim warranty and service you should always fill out this form, at least at delivery and service. This signed form declares that the end user had an instruction on the operation of the scooter bike, that the scooter bike is adjusted to the specifications of the end user and that the user manual is received.

### Fill out when the scooter bike is delivered

Type Van Raam scooter bike:	
Frame number:	
Key number:	
Delivered to:	
By dealer:	
Place:	
Date:	
Signature user bike:	Signature dealer:
When available, stamp dealer:	